

# EPAL 2 INDUSTRIAL PALLET

1,200 x 1,000 mm



The work of the European Pallet Association, its National Committees and licensees forms the stable basis for the successful, open pallet pool and enables the global exchange of EPAL load carriers. There are more than 650 million EPAL pallets in circulation around the globe that are used throughout the sector and it would be impossible to imagine industry and logistics without them. The design of the EPAL 2 industrial pallet makes it ideal for the heaviest of industrial loads. The perimeter base allows it to be transported on chains or roller conveyors. Constant quality assurance and high quality materials ensure trouble-free, safe performance for users and loading. Their multiple use saves a considerable amount of environmental and economic resources.

## FACTS & FIGURES

Materials: 17 boards of quality timber, 9 wood-chip or solid wood blocks, 133 nails. Produced according to the EPAL Technical Regulations.

<b>Length</b>	1,200 mm
<b>Width</b>	1,000 mm
<b>Height</b>	162 mm
<b>Weight</b>	Approx. 35 kg
<b>Safe working load</b>	1,250 kg

When stacking laden pallets on a solid, even surface, the bottommost pallet must not exceed a load of max. 4,250 kg.

## QUALITY CONTROL

The international pool of EPAL load carriers is the only load carrier pool in the world subject to independent quality assurance by external inspection companies. This is the only way for EPAL load carriers to guarantee the consistently high quality that they offer the markets.



## MARKINGS



"EPAL in oval" on the left and right corner block (since 08/2013).

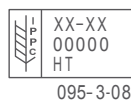

IPPC symbol, country code, registration number of the national plant protection authority, heat treatment, licence number-year-month on the central block.



EPAL control staples

## ISPM 15



Compliance with the ISPM 15 standard is the most essential condition for the unrestricted use of load carriers in the international movement of goods. All EPAL load carriers are therefore produced according to the stringent specifications of the IPPC and can thus be deployed around the globe. Local plant protection agencies will provide information on the countries that recognise the IPPC standard.

## HANDLING

4-sided accessibility with chamfered lower edge boards on both sides enables highly efficient handling during production, storage and transportation all the way along the supply chain. Compatible with all (conventional) standard load carriers, industrial trucks and warehouse systems.

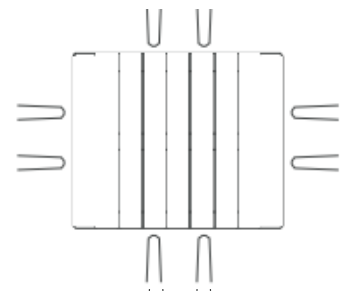

## REPAIR



Damaged EPAL pallets can be repaired cost effectively and in a climate-friendly manner by all EPAL-licensed pallet repair operations. EPAL pallets repaired according to standard receive a repair marking nail bearing the "EPAL" trademark and the licence number of the repair operation, following the quality-assured repair.



# EPAL 2 INDUSTRIAL PALLET

1,200 x 1,000 mm



1,000 mm side

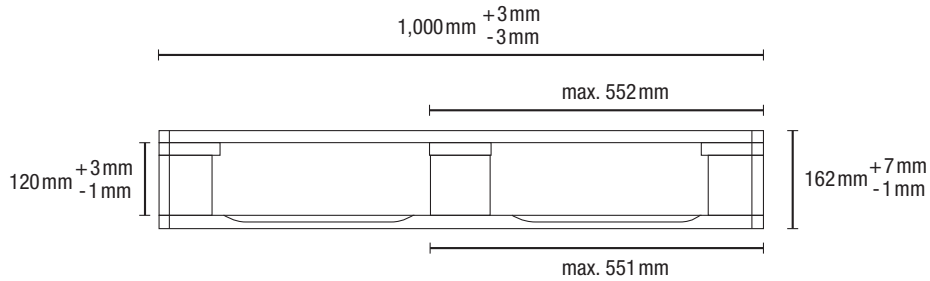

1,200 mm side

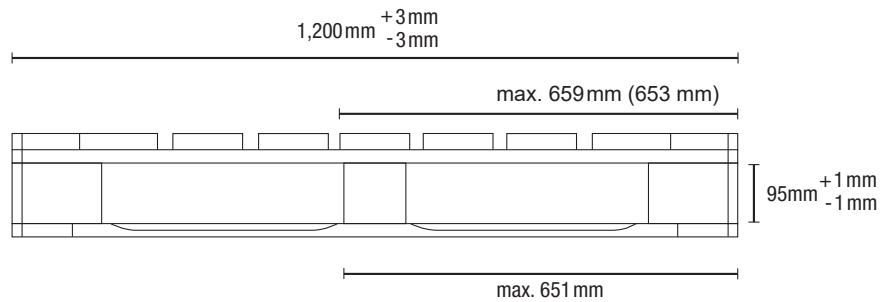

Top view

